



# Safe Use of Chainsaws

Salim Hiziroglu  
Assistant Professor Forestry

Bill Ross  
Assistant Professor/ Extension Forestry Specialist

Oklahoma Cooperative Extension Fact Sheets  
are also available on our website at:  
<http://osufacts.okstate.edu>

A chainsaw is a highly versatile piece of equipment which is used for many applications, ranging from felling trees to cutting firewood. Chainsaws are also extremely dangerous. Accidents and injuries can result from improper use. Chainsaw accidents are commonly caused by contact with the chainsaw blade, while it is running. As with any equipment, chainsaws can only be used efficiently and effectively if safety and protection rules are closely followed. Some of the basic operating principles and safety aspects of the chainsaw are summarized in this fact sheet.

Chainsaw operators should match the saw to the job. Size of the saw should be determined based on the type of cutting. For example small, lightweight chainsaws, generally weighing less than 10 pounds, are best for pruning and cutting very small trees, whereas saws weighing 15 pounds or more, with up to 20 inch cutting bars, are suitable for large trees. Weight of the saw is also important for efficient cutting. Heavy saws result in extreme fatigue if they are used for a long period of time.

Figure 1 illustrates components of a typical chainsaw.

**Before any cutting is done the following procedures should be followed :**

1. Read the chainsaw instruction manual.
2. Wear the proper clothing, head, hearing, and eye protection.
3. Make sure the saw is in good working condition. The saw should be cleaned and properly lubricated. Cutting edges should be kept sharp.
4. Inspect the chain for damaged or broken teeth.
5. The saw should be checked for proper chain tension.

**Personal Protection Requirements**

1. **Safety helmet (hard hat):** Safety helmets protect the head against any possible falling limbs or branches. There are different types of hardhats on the commercial market. Some of them include built-in hearing and/or eye protection. Hardhats should also be replaced, according to manufacturers' instructions, every three to four years.

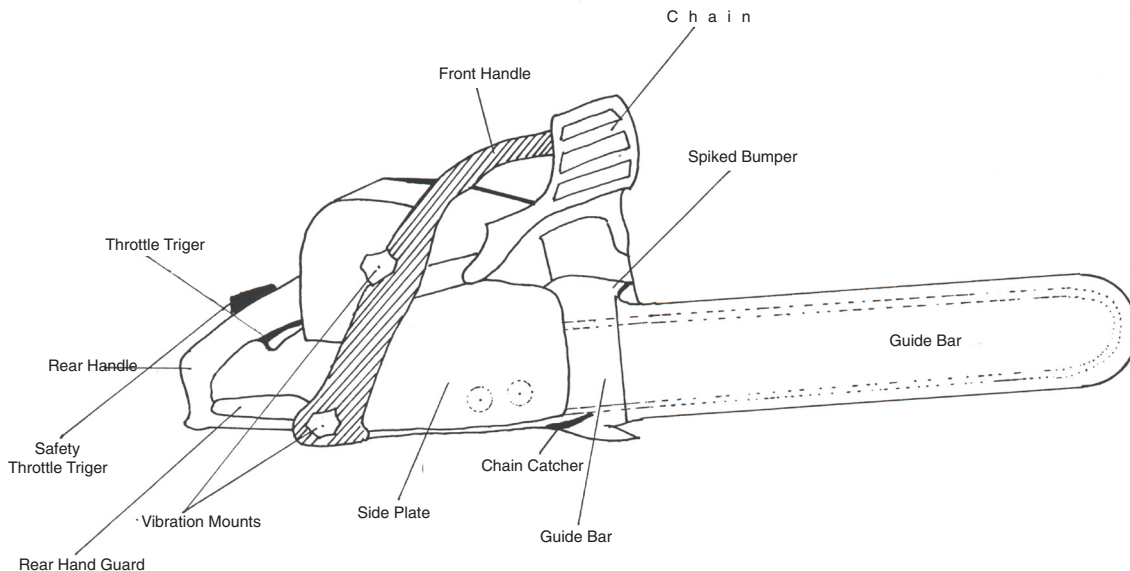
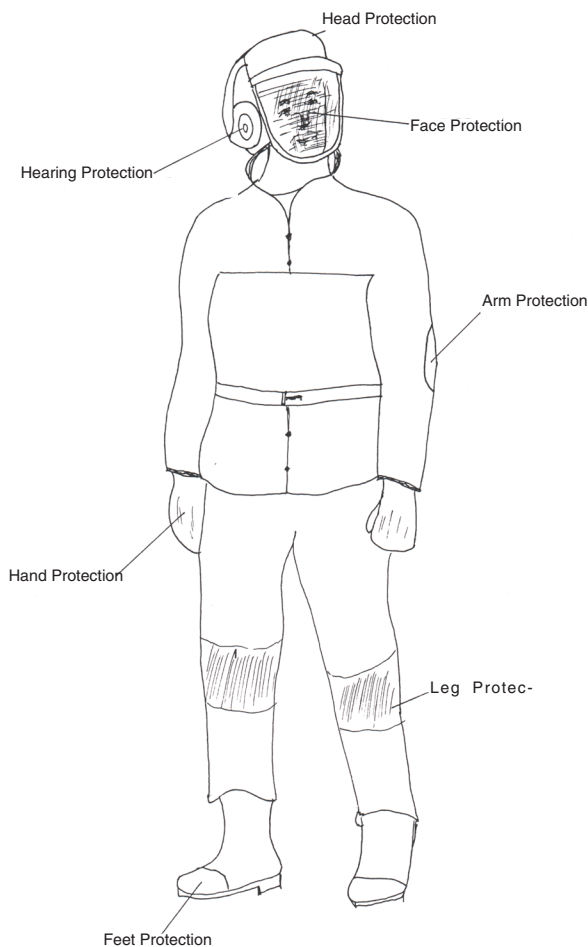

Figure 1. Components of a typical chainsaw.

2. **Hearing protection:** Chainsaws may produce noise up to 120 to 130 decibels. In addition to possible long-term hearing loss, exposure to that level of noise for a long time may easily cause operator fatigue. Therefore, ear muffs must be worn to reduce accidents and protect hearing.
3. **Eye Protection:** Goggles are most commonly used for eye protection in chainsaw operation. However, face screens are also very useful and they are designed to deflect or stop small particles such as wood chips. The best protection includes the use of both goggles or safety glasses and a face screen. In fact, OSHA does not recognize the face screen itself as adequate protection for most saw operations.
4. **Clothing :** Proper clothing is neglected by many chainsaw operators. Tight but flexible clothing is ideal for operators. Leg, arm, and hand protectors made from woven nylon, Kevlar fiber, or similar material are highly recommended. Steel toed boots are also useful. Personal safety protection is illustrated in Figure 2.

## Chainsaw Operating Principles

All chainsaws should be equipped with a **hand guard and chain brake**. The chain brake can be used as a parking brake when the saw is started and moved between different



**Figure 2. Personal protection gear for chainsaw operators.**

cutting locations or configurations. Personal injuries can be reduced substantially by having a chain brake. The brake also acts as a safety device by stopping the chain rotation if a kickback occurs during cutting. A **throttle trigger lockout unit** is another important element of a chainsaw. This assures an operator's right hand is in the throttle use position before the saw can be accelerated. The stop switch should be located within thumb reach of the operator. As soon as cutting is completed the saw should be turned off to eliminate possible accidents. **Before starting the saw**, the engine oil, air filter, sprocket, and cooling fins should be checked for possible blockage. **Length of the bar** is important and should be selected based on the power of the chainsaw.

**Correct chain tension** is also a very important factor influencing proper cutting. A chain that is too loose will derail during cutting. On the other hand, if the chain is too tight it will bind and can result in an accident. To adjust the chain the saw's rear bar mounting nut is tightened, while the saw is held nose up and then the front mounting nut is tightened.

**Starting a chainsaw** improperly can cause serious accidents. The chainsaw should be started on the ground, while placing one hand on the front handle and the inside of one knee on the rear handle. This method is the safest way to give the operator good control over the chainsaw during the start. Starting the chainsaw by dropping is not only dangerous resulting in possible injury, but also may damage the saw. Before any cutting is performed, the chain should be run on the guide bar for about one minute at a fast idle speed and then tensioned for an optimal sawing.

**Kickback and pull-in** are two important factors caused by reactive forces in chainsaw operation. Unless the fundamental concepts behind these reactive forces are clearly understood, major injuries are possible. Kickback occurs when the rotating saw suddenly hits a solid object or the chain is pinched in a cut in the upper 50 percent of the saw tip. This can force the saw backward resulting in a serious accident. Kickback injuries can be prevented by holding the saw firmly with both hands, gripping the top handle with the thumb wrapped around it, and keeping saw speed fast when entering or leaving a cut. It also helps to keep the chainsaw properly sharpened. Many improved models of chainsaws are equipped with a safety tip or special chain which has an antikickback feature. Chainsaws can kickback for many reasons. The most common cause of kickback is catching a small hidden limb in the upper quadrant of the nose bar. Figure 3 show causes of kick-back.

### Additional causes of kickbacks

1. Slow running speed.
2. Accumulation of damp sawdust on the chain.
3. Twisting the saw so that the cutter grabs in the wood.
4. Extreme changes in wood characteristics, density, moisture, and defects.
5. Improper filing of the chain.
6. Improper tension on the chain.

Pull-in is another cause of cutting accidents, but it is usually overlooked. During normal cutting, with the lower side of the guide bar that has a pulling chain, an operator could find the saw unbalanced. When a saw becomes bound, an operator may lose control. Depth gauges and tooth angles should be set according to the manufacturer's recommendation and specification. The operator should make sure the motor

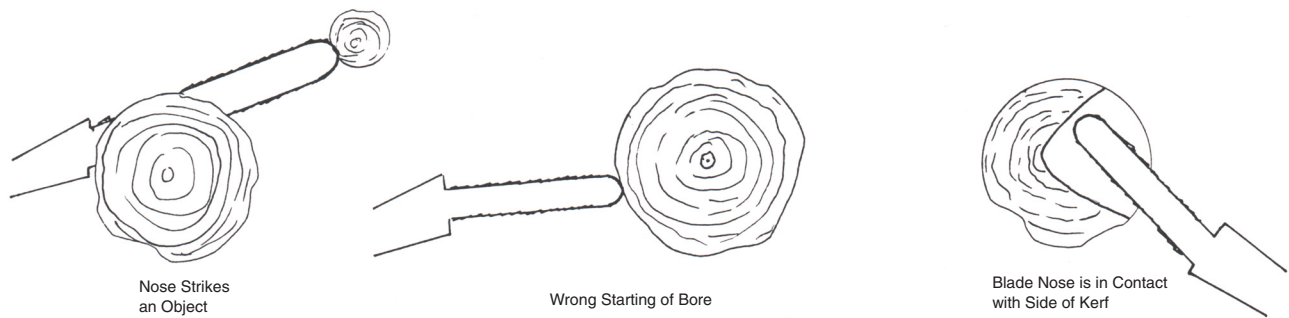

**Figure 3. Causes of kick-backs.**

switch is turned off and the spark plug wire is disconnected to prevent any accidental starting of the chainsaw.

### Chainsaw Maintenance

Proper maintenance plays a very important role in efficient use of the chainsaw. Maintenance of the chainsaw can be classified into various tasks, namely break-in, daily operation maintenance, and periodic maintenance. During break-in the chain should be soaked in oil before putting it on the guide bar to ensure oil gets into the rivet holes.

Proper lubrication also will prolong chain life. The user should make certain that the automatic oiler is properly adjusted and does not over-or under-oil when in use. If the bar oiling mechanism plugs up and it is not corrected, serious damage can occur. Periodically, operators should shut off the engine and pump the oiler while pulling the chain around by hand, which will ensure even distribution of oil on the chain.

In addition to proper tensioning, chain sharpening plays a significant role in cutting efficiency. Dull chains require unnecessary effort to cut wood. Depending on length of time used and tree species cut, the frequency of saw tooth sharpening will vary. Approximately 20 percent of the file diameter should be held above the cutter's top plate if a round file is used for sharpening as illustrated in Figure 3. If there is damage to the blade surface of the top plate, it should be filed until the damage is completely removed.

**Daily operation maintenance** is vital to prevent accidents. The chainsaw should be cleaned after each day's use. An air hose should be used to blow out dirt, which may have collected on the chain. The body of the saw should also be

inspected for any loose or missing parts, which may cause a major problem during cutting. The fuel and air filters should be inspected according to manual guidelines.

**Periodic maintenance** should also be carried out to keep the chainsaw in good condition. The fuel tank should be drained and cleaned by flushing at least once a year. The cooling air intake should be inspected and cleaned frequently. The starter cord is an important part of the chainsaw and it should be regularly checked to be sure it is properly rewound on the coil.

### Felling a Tree with Chainsaw

Felling a tree is the most hazardous of all logging activities. Almost 55 percent of accidents in harvesting take place during the felling and bucking. Consequently, tree felling should never be attempted alone or by untrained individuals. Considerable attention is required when a tree is cut in order to prevent injury and to avoid wood damage due to breakage and splintering. There are various types of undercuts used in felling. The purpose of an undercut is to assist in controlling the direction of fall. Splintering could happen if the undercut is too shallow, reducing the amount and quality of usable wood. Once the undercut is completed, a backcut is made approximately 1 to 2 inches above the top of the undercut and perpendicular to the longitudinal axis of the tree. If the tree still does not fall when the backcut is done, a wedge should be used to further the chainsaw within the cutting surface.

The 90 degrees hinge method is also widely used in felling. Approximately 1/3 of the tree diameter hinge is cut before back cut is performed. This technique eliminates possible

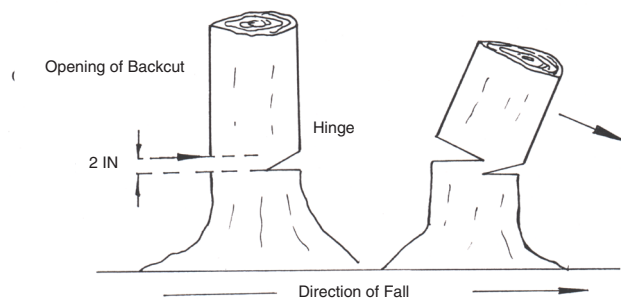

**Figure 4A. Conventional undercut felling.**

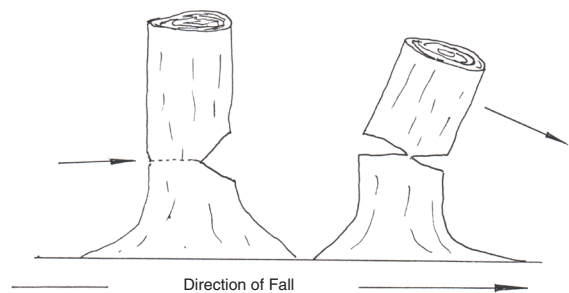

**Figure 4B. Hinge method felling.**

reduction in the nominal length of some boards from the top face due to the notch in conventional undercut. The conventional undercut and 90 degree hinge methods are illustrated in Figures 4A and 4B, respectively.

Detailed descriptions of tree felling and bucking techniques are discussed in a separate fact sheet.

**Further information about the safe use of chainsaws can also be obtained in the following publications.**

Conway, S. 1892. Logging Practices. Principles of Timber Harvesting systems. Miller Freeman Publication Inc. San Francisco, CA.

Conway, S. 1974. Timber Cutting Practices. Miller Freeman Publication Inc. San Francisco, CA.

Petro, F.J. 1975. Felling and Bucking Hardwoods. How to improve your profit. Department of the Environment Service. Publication No. 1291.

Stenzel, G., T. Walbridge, and K. Pearce. 1985. Logging and Pulpwood Production. John Wiley & Sons Inc.

Oklahoma State University, in compliance with Title VI and VII of the Civil Rights Act of 1964, Executive Order 11246 as amended, Title IX of the Education Amendments of 1972, Americans with Disabilities Act of 1990, and other federal laws and regulations, does not discriminate on the basis of race, color, national origin, gender, age, religion, disability, or status as a veteran in any of its policies, practices, or procedures. This includes but is not limited to admissions, employment, financial aid, and educational services.

Issued in furtherance of Cooperative Extension work, acts of May 8 and June 30, 1914, in cooperation with the U.S. Department of Agriculture, Robert E. Whitson, Director of Cooperative Extension Service, Oklahoma State University, Stillwater, Oklahoma. This publication is printed and issued by Oklahoma State University as authorized by the Vice President, Dean, and Director of the Division of Agricultural Sciences and Natural Resources and has been prepared and distributed at a cost of 20 cents per copy. 0607