



# Livestock Branding in Oklahoma

**David Lalman**  
Extension Beef Cattle Specialist

**Cassie Danielson**  
Brand Registrar, Oklahoma Cattlemen's Association

**Michael Kelsey**  
Executive Vice President  
Oklahoma Cattlemen's Association

Oklahoma Cooperative Extension Fact Sheets  
are also available on our website at:  
**facts.okstate.edu**

The beef cattle industry is a dynamic business that must continually adjust to market signals, public opinion, state and national policies, and other industry issues. Branding cattle to show ownership, legal title, and record keeping have been promoted and practiced by cattlemen in the western states for the past 150 years. However, in recent years, questions have been raised concerning the humane treatment of cattle with respect to certain management practices, and the impact of those practices on the overall value of a beef product and/or by-products.

According to the 2016 National Beef Quality Audit, of the \$49.06 lost per head to the beef industry due to discounts for various carcass defects, and quality issues, only 98 cents of that loss was due to brands and/or other hide defects. This reduction in value (price) due to hide defects is compatible to \$1.95; 1.90; 2.39; 2.67 and 2.43 in beef quality audits conducted in 2011, 2005, 2000, 1995 and 1991, respectively. This improvement suggests that more producers have moved the location of the brand from the rib to the hip, thus restoring more value to the hide.

The 2007-2008 USDA National Animal Health Monitoring System study of 2,872 beef cow/calf operations in 24 of the nation's major beef-producing states represented 80 percent of all cow/calf operations, and 88 percent of all the beef cows in the U.S. The study showed that the hot iron brand was used on 12 percent of all the operations and was the source of identification on 21 percent of all the cows in the study. The freeze brand was used on 2.4 percent of all the operations surveyed, and identified 4 percent of all the cattle in the study.

## Why Brand?

Branding today is still the most recognized and accepted means of indicating ownership of cattle in North America. Eventually, other methods such as electronic "chipping" may become the standard for identification, but until this procedure becomes a more economical and practical alternative, producers will continue to utilize the time-tested, permanent and universal method of branding.

## Summary of Oklahoma Brand Laws

Those applying for state brand registration must complete and file the Application for Registration of Brands and Marks (found at: <http://www.okcattlemen.org/brand-registration>) with

the Oklahoma Cattlemen's Association Brand Division, P.O. Box 82395, Oklahoma City, Oklahoma 73148. The application must be accompanied by a \$40.00 registration fee. Upon approval, a brand certificate will be mailed to the applicant indicating the brand registered. All brands approved by the Oklahoma Cattlemen's Association (OCA) will appear in the following brand book or supplement printed.

All brands must be renewed at the beginning of each five year registration period, regardless of when the brand was registered. State registered brand owners will be notified by mail before the five year registration period ends. At this time, brands are renewed prior to publication of the newest Oklahoma Brand Book.

1. A brand is defined as a permanent mark not less than three inches in length or diameter and burned into the hide with a hot iron. "Freeze branding" is also a form of identifying animal ownership. Acid brands are not recognized as state registration.
2. Single unit brands including one initial, number, bar, slash or quarter circle are not accepted as forms of state registration.
3. Each brand registration must be confined to one location on the animal. When the same brand is used on two sites, two applications must be filed. Brands must be registered in the following eight positions ONLY: left neck, left shoulder, left rib, left hip, right neck, right shoulder, right rib and right hip. However, previously registered Oklahoma brand positions are not affected (O.S. 2, Sections 405). The left jaw is reserved for the use of B and T brands, identifying cattle having a detectable antibody titer for Brucellosis and Tuberculosis.
4. Applicants are required by law to list, in order of preference, three distinct brands and three positions on the animal for application of the brand.
5. State registration of your brand is not required by law. Recorded brands, however, take precedence over similar unrecorded brands when questions of ownership arise, placing the burden of proof on unregistered brand users in the event of controversy. Registered brands are prima facie evidence of ownership in a court of law.

Brand books are furnished to county sheriffs, county extension agents, vocational agricultural instructors, and libraries without charge. They can be purchased by the public from OCA at a price equal to the cost of preparation, printing, and delivery.

## Where, When and How to Brand

When ownership brands are applied it is best to use hot brands. The clarity of the application can be determined shortly

after branding, and animal-to-animal variation does not affect the end results as greatly as with freeze branding. A good hot brand is recognizable because it destroys hair follicles located under several layers of skin and leaves a permanent bald scar on the hide of the animal.

Identification and ownership brands can be applied at any time during the year, but this procedure is usually performed in combination with one or more practices such as weaning, castration and vaccination. Calves are usually branded before or during weaning because the probability of a calf straying is greater after weaning.

Good brands can be achieved by properly heating the irons until they appear a silvery-gray (similar to the color of ashes) in the daylight, but glow a cherry-red color when held in a dark area. Clipping excessive hair growth or mud from the hide area to be branded, and keeping irons clean at all times with a steel brush to remove hair, dirt and other debris are management practices which should be utilized. The irons can be heated in a wood fire (bed of coals) or a propane (bottled) gas fire. An electric branding iron can be used successfully after a certain amount of experience is gained.

The size of the iron is important. Each character should be (in outside measurements) 4 inches by 3 inches for calves less than one year old and 6 inches by 3 1/2 inches for older cattle. The face width of the branding iron should be 1/4 inch to 1/2 inch wide, with the surface edges slightly rounded. All circles and corners should be vented to prevent excessive scarring. Again, in utilizing the "value added" approach, the branding location is restricted to the hip. This should be the first consideration, as the brand registry may require an applicant to move their chosen location (thigh, shoulder) or choose a different design in order for the brand to be registered.

## Tips on Fire Branding Procedures

Catch the calf's head in the headgate of a squeeze chute, then squeeze to restrict motion. Heat the branding irons to the proper temperature as previously described. Firmly press the ash-gray colored branding iron against the hide and rock the handle slightly to vary the pressure, allowing for uniform application of the entire character.

The color of the branded hide should be light tan, similar to the color of new saddle leather. If the iron is the proper temperature and the cattle have a light (summer) hair coat, the brand should be held for no more than three to five seconds. Cattle with a heavy (winter) hair coat should be clipped before branding. Otherwise, the brand requires an application of five to ten seconds.

Do not brand wet animals. An iron applied to a wet animal loses temperature rapidly and tends to scald rather than burn the hide. The result is a serious, slow-healing scar that is hard to read. Apply one iron at a time, taking caution to avoid slippage on the hide. Place brand numbers or characters at least one inch apart. Be sure the branding iron is clean and free of hair before it is used again.

If a second application is necessary to "touch-up" a spot, or more burn is needed, the procedure should be done with extreme care. The iron must be placed in the exact position of the first application so the character does not blotch.

It is best to brand when flies are not a problem. If they are present, apply a small amount of insecticide to the brand area to prevent infection. A light application of oil or grease to the area will also aid in smoother, faster peeling.

## Freeze Branding

Freeze branding (cryogenic branding) of cattle with super-chilled irons has been developed within the past 30 years, and is recognized as a legal method of ownership and animal identification in Oklahoma. With this method, the hair of a freeze branded animal is discolored or white due to damage by contact with extreme cold to the melanocytes (color producing cells) of the hair. However, the Oklahoma Cattlemen's Association recommends that hot iron brands be used for ownership purposes.

Freeze branding has not fulfilled all of the early expectations for the technique, though some people have been satisfied with the results. Drawbacks of the process include:

- 1) Brand sites need to be clipped in the winter for complete clarity.
- 2) The process is relatively expensive on small numbers of cattle.
- 3) Visibility of the brand is not as distinct on yellow, white, or red cattle as on black cattle.

Freeze branding materials include:

- 1) Hair clippers, brush, and squirt bottle.
- 2) Branding irons (preferably copper, or brass heads).
- 3) Insulated container for coolant.
- 4) Alcohol (95 percent ethyl, methyl or isopropyl) or acetone.
- 5) Dry ice or liquid nitrogen.

## Tips on Freeze Branding Procedures

Factors critical to the success of freeze branding include properly cooled irons, uniform pressure on the brand site, and correct timing.

Key steps of the procedure include:

- 1) Cool irons in alcohol and dry ice or liquid nitrogen.
- 2) Restrain the animal in a headgate and squeeze chute.
- 3) Clip area to be branded closely.
- 4) Clean brand site by brushing and wet thoroughly with alcohol from a squirt bottle or sponge.
- 5) Firmly hold the iron in place on the brand site for the necessary time.

---

Timing	Calves	Mature Cattle
Alcohol and Dry Ice	40 seconds	60 seconds
Liquid Nitrogen	10-15 seconds	22-25 seconds

---

## How to Read a Brand



























Brands are read from left to right, top to bottom and outside to inside. Figures, symbols, letters, and numbers will become easily recognizable with practice (see Figure 1). An alternative to the more customary and traditional brand symbols is the angle brand system (see Figure 2). This universal identification system is based on two concentric squares designed by USDA Agricultural Research Service workers.

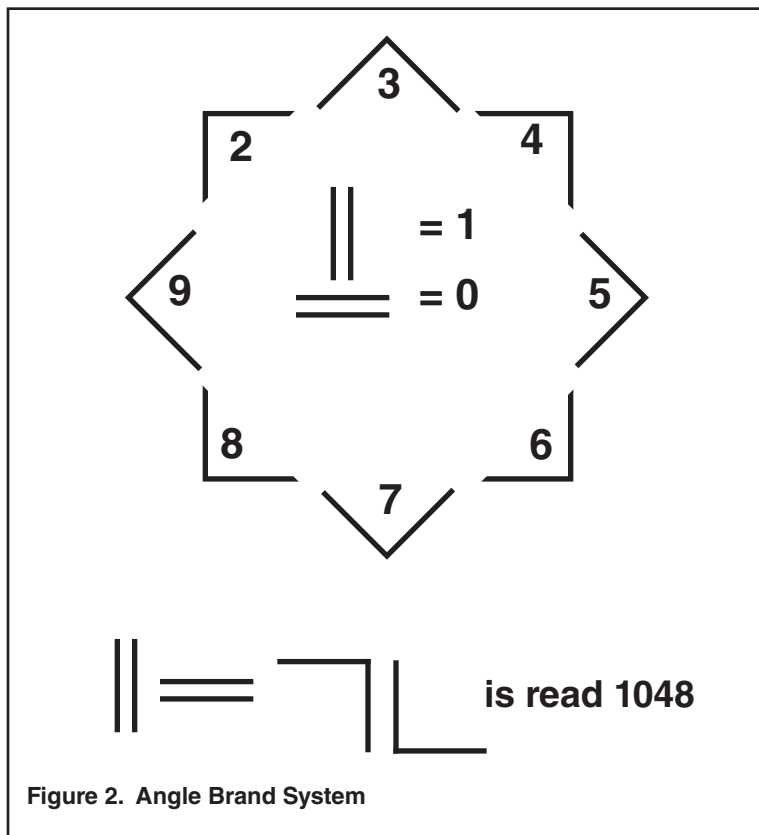
In the basic square, numbering starts with 2 (in the top left corner) and continues clockwise to the other three corners as 4, 6 and 8. Odd numbered angles are indicated by a second square rotated 1/8 of a turn to the right (clockwise). The top angle (corner of second square) is designated as the number 3 with the 5, 7 and 9 angles following in the same clockwise manner. Two adjacent vertical lines, as with the number "11," represents the number 1. Two adjacent horizontal lines, or an "equals" sign (=), depicts the number 0.

These identification marks can be applied with either hot or cold branding techniques. Furthermore, these angles proved to be more easily read than numbers in recognition trials.

The following examples should give you an idea to help get you started.

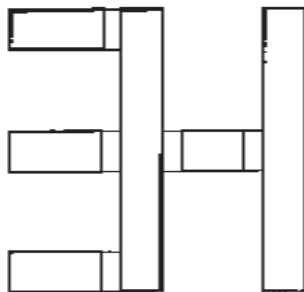
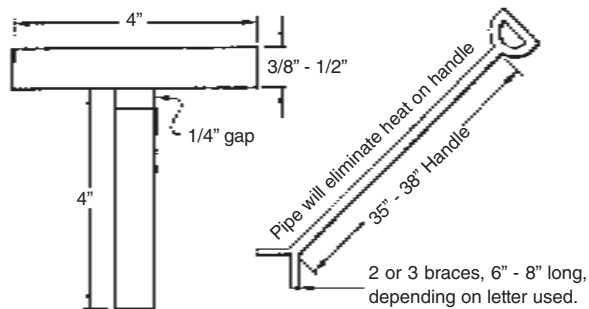
**Figure 1. Traditional Brand Symbols**

Bar, a short, horizontal line.		Tumbling or tilting brands are no longer registered. Brands must be straight up or lazy.		Often letters or letters and numerals are "connected." This is a "J.H.D. Connected."	
Bar, straight up is an "i."		Add legs and it becomes "Walking T."		Placed on part of a circle, it becomes a "Rocking M."	
Slash, a line slanting right or left.		Add wings, it's a "Flying T."		This is the "Running M."	
Box.		Any letter hanging by its top "Swings." A "Swinging M."		TVD connected	
These are read "half box."		BVT connected.		"KDH" connected.	
But this may read "bench."		"J.H.D. Disconnected."		Stacked letters are easy to read.	
Circle, (Filed with the OCA under "O").					
Half circle, may open up or down.					
Quarter circle, may be in any position.					
Cross or plus.					
May be X or roman numeral 10 as in XIT, "Ten in Texas," but is filed under "X."					
Diamond.					
Open "A" (not half diamond).					
But placed over a letter or number, it's a "Rafter", and filed behind "A."					

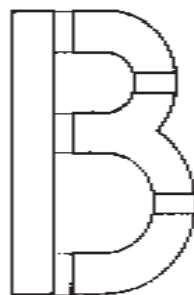


**Figure 2. Angle Brand System**

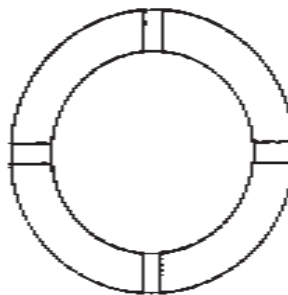
**Figure 3. Constructing and Branding Iron.**



It is not recommended that brands of this type be combined in one iron. Otherwise, they are hard to handle and difficult to apply on the animal evenly. Separate irons for the E and a running iron for the H may take longer to make, but the results will be well worth the time.

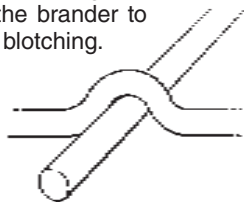


This B iron is made into one piece and has five gaps cut into the face to allow extra heat to escape, therefore eliminating blotching. Another method of making a B is to use a 3 and a bar iron (13).

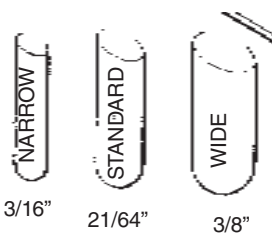
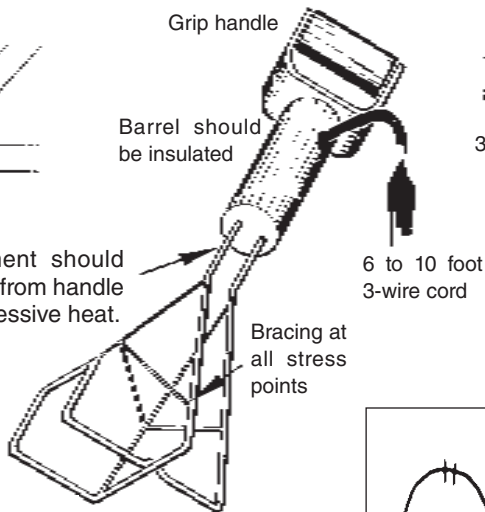


The letter O has gaps to allow heat to escape. It is recommended that branding irons of this nature be made slightly larger than those consisting of straight lines to eliminate blotching.

Adequate spacing should be allowed when intersecting the face of the brander to prevent blotching.

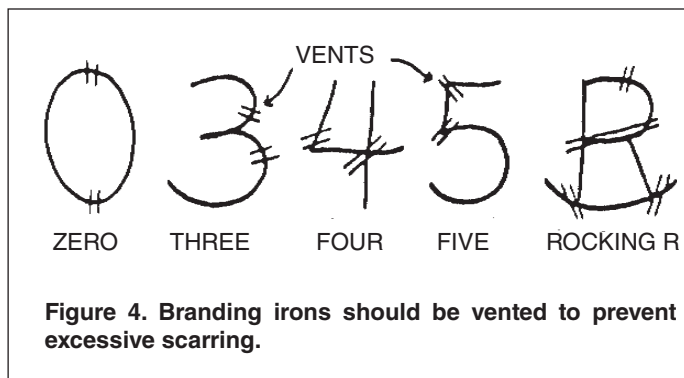


Heating element should be far enough from handle to prevent excessive heat.



Electric branders are available with three different width faces: NARROW for horses, STANDARD for general use, and WIDE for heavy hair growth in northern areas.

Approximate heating time for electric branders is 90 seconds. Blotching is minimal, as the design allows excessive heat to escape. Extensive venting is unnecessary on most brands. Operated on 110 volt AC or DC, a constant temperature is characteristic.



**Figure 4. Branding irons should be vented to prevent excessive scarring.**

Oklahoma State University, in compliance with Title VI and VII of the Civil Rights Act of 1964, Executive Order 11246 as amended, and Title IX of the Education Amendments of 1972 (Higher Education Act), the Americans with Disabilities Act of 1990, and other federal and state laws and regulations, does not discriminate on the basis of race, color, national origin, genetic information, sex, age, sexual orientation, gender identity, religion, disability, or status as a veteran, in any of its policies, practices or procedures. This provision includes, but is not limited to admissions, employment, financial aid, and educational services. The Director of Equal Opportunity, 408 Whitehurst, OSU, Stillwater, OK 74078-1035; Phone 405-744-5371; email: [eeo@okstate.edu](mailto:eeo@okstate.edu) has been designated to handle inquiries regarding non-discrimination policies; Director of Equal Opportunity. Any person (student, faculty, or staff) who believes that discriminatory practices have been engaged in based on gender may discuss his or her concerns and file informal or formal complaints of possible violations of Title IX with OSU's Title IX Coordinator 405-744-9154.

Issued in furtherance of Cooperative Extension work, acts of May 8 and June 30, 1914, in cooperation with the U.S. Department of Agriculture, Director of Oklahoma Cooperative Extension Service, Oklahoma State University, Stillwater, Oklahoma. This publication is printed and issued by Oklahoma State University as authorized by the Vice President for Agricultural Programs and has been prepared and distributed at a cost of 20 cents per copy. Revised 0618 GH.